

RAPTOR IP65 EMERGENCY



Prolight Design offers bespoke lighting solutions for some of the UK's largest retailers. From conceptual design to installation and beyond, we cover every element of retail lighting under one roof.

Compact modern twin spot emergency suitable for industrial applications.

Specification		Warranty Terms
Lumen Output	215L	5 Years
Colour Temperature	6500K	
Protection	IP65	
Colour	White	
Input Voltage	230V	
Energy Consumption	1.8W	

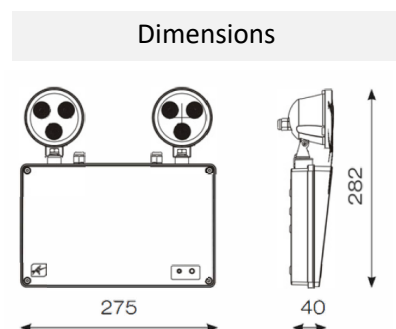

This product has a warranty period of 5 Years from the date of purchase. The warranty is invalid in the case of improper use, installation, tampering, and removal of the Q.C. date label; installation in an improper working environment or installation not according to the current edition of the National Electric Code. Should this product fail during the warranty period it will be replaced free of charge, subject to the correct installation of the original product and subsequent return of the faulty unit.

Prolight reserves the right to alter specifications without prior notice.